



10. DC Oil Coolers

This page describes our DC range of oil coolers which are designed for use on small marine transmissions. They have the same cupro-nickel tubes as our larger EC to PK range of oil coolers and therefore have the same long life expectancy.

The seawater connections are neoprene mouldings making them simple and easy to install and should cleaning be necessary, they can be removed using only a screwdriver.

We can select by computer the appropriate oil cooler for a particular duty from the following information.

oil type or its viscosity at a specified temperature	cSt at °C
heat to be dissipated	kW
oil flow	liter/min
oil inlet temperature	°C
seawater temperature	°C
seawater flow	liter/min

If this information is not available, a selection can be made using the table below. In many cases we will have on file information which will enable us to select a suitable oil cooler for a particular engine and gearbox combination.

Two oil connection sizes are available and three seawater pipe sizes which can be either in line or at right angles to the axis of the cooler. If preferred, the oil coolers can be supplied without end covers for incorporating directly into the seawater pipework.

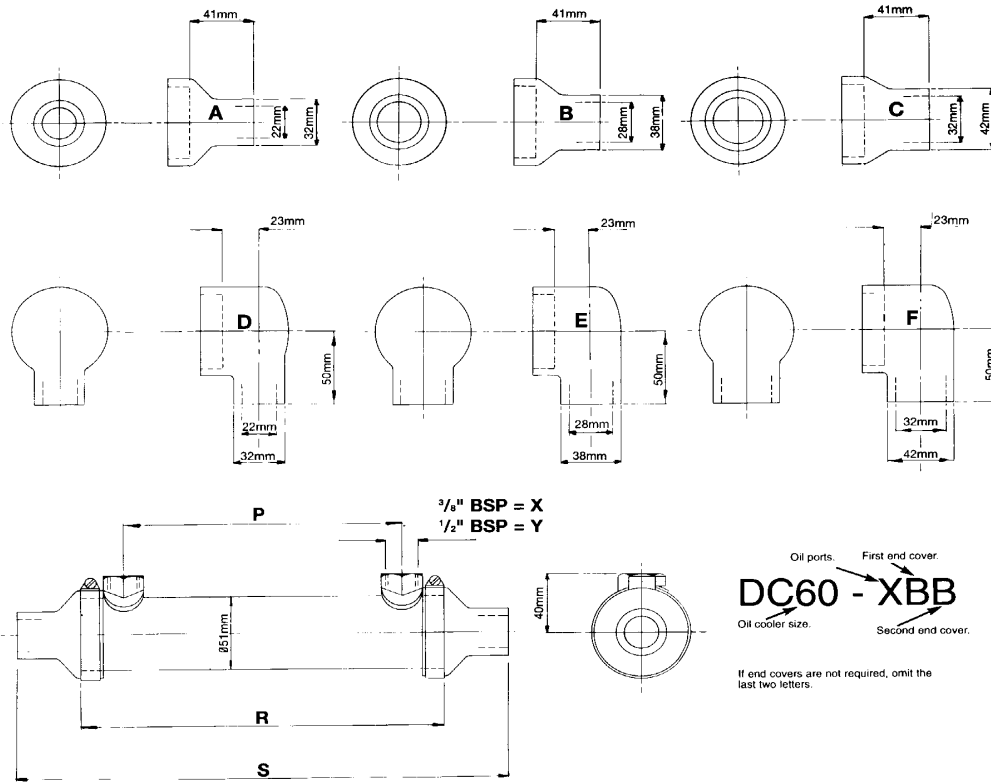

Type	P mm	R mm	S mm	Internal oil volume ml	Internal water volume ml
DC 50	69	123	205	80	160
DC 60	104	158	240	105	200
DC 90	178	232	314	160	240
DC120	260	314	396	200	325

Maximum working oil pressure 25 bar
Maximum working water pressure 3 bar
Maximum working temperature 125°C

Typical examples of oil coolers fitted to marine transmissions with an oil inlet temperature of 80°C and a sea water temperature of 32°C.

Type	Maximum sea water flow for end cover code				Suitable for gearbox transmitting	
	A + D l/min	B + E l/min	C + F l/min	None l/min	kW	Hp
DC 50	60	90	120	180	75 - 100	
DC 60	60	90	120	180	120 - 160	
DC 90	60	90	120	180	150 - 200	
DC120	60	90	120	180	180 - 240	